

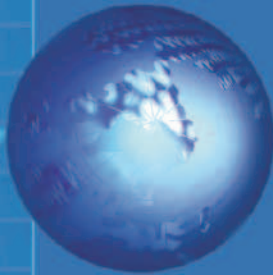

新型縫袋口機系列

NEW TYPE BAG CLOSING MACHINE

NEW





手提式縫袋口機系列 Portable Bag Closer

特性：

- 最高速度 1600 ~ 1800 s.p.m.
- 提高效率技術革命
- 特殊材料安全手把
- 高壓強力加油系統
- 維護費用低
- 機動切線
- 低音轉動
- 可用於紙袋、麻袋、塑膠編織袋、麵粉袋、棉袋、PP 袋和 PE 袋等

Features :

- Max, sewing speed 1600~1800 s.p.m.
- More effective for technical revolution.
- Special material for safety plastic handle.
- Superior powerful lubricator.
- Mechanical thread trimmer.
- Lower noise.
- Minimum maintenance.
- For bag closing all kinds of paper, cotton, PP/PE, hessian, jute, etc.

N620A

雙針雙線
2-thread



N640A

雙針四線
4-thread



台灣專利號碼：M425132
TAIWAN patent NO. : M425132

規格 Specifications

| 機種 Model | 線數 Thread | 縫速 Speed | 縫距 Stitch | 使用針 Needle | 切線 Cutter | 淨重 N.W. | 毛重 G.W. |
|-------------|--------------|------------------------|--------------|----------------|----------------------------------|------------|------------|
| N620A | 2 | 250 ~ 350 Bags/Hour | 7.2 mm | FD - 5 # 25 | 機動切線 Mechanical Thread Cutter | 6.8 kg | 8.2 kg |
| N640A | 4 | 250 ~ 350 Bags/Hour | 7.2 mm | FD - 5 # 25 | 機動切線 Mechanical Thread Cutter | 7.2 kg | 8.8 kg |

馬達 Drive motor 90W 50 / 60Hz, 1ph / 12V, 24V, 110V, 115V, 220V, 230V, or 240V
(敬請指定 Please specify one when order)



手提式縫袋口機系列 Portable Bag Closer

N600A · N600H

單線
1-thread

單線高速
1-thread
High Speed



N602A · N602H

雙線
2-thread

雙線高速
2-thread
High Speed

規格 Specifications

| 機種 Model | 線數 Thread | 縫速 Speed | 縫距 Stitch | 使用針 Needle | 切線 Cutter | 淨重 N.W. | 毛重 G.W. |
|-------------|--------------|------------------------|--------------|----------------|----------------------------------|------------|------------|
| N600A | 1 | 250 ~ 350 Bags/Hour | 7.2 mm | DN x 1 # 25 | 機動切線 Mechanical Thread Cutter | 6.1 kg | 7.5 kg |
| N600H | 1 | 350 ~ 450 Bags/Hour | 7.2 mm | DN x 1 # 25 | 機動切線 Mechanical Thread Cutter | 6.1 kg | 7.5 kg |
| N602A | 2 | 250 ~ 350 Bags/Hour | 7.2 mm | DN x 1 # 25 | 機動切線 Mechanical Thread Cutter | 6.7 kg | 8.1 kg |
| N602H | 2 | 350 ~ 450 Bags/Hour | 7.2 mm | DN x 1 # 25 | 機動切線 Mechanical Thread Cutter | 6.7 kg | 8.1 kg |

馬達 Drive motor 90W 50 / 60Hz, 1ph / 12V, 24V, 110V, 115V, 220V, 230V, or 240V
(敬請指定 Please specify one when order)



手提式縫袋口機系列 Portable Bag Closer

特性：

- 此機種附有喇叭裝置，紙帶條可同時縫入袋口增加縫袋包的密封性與強度，尤其是對粉末狀產品更能夠完全緊密封裝，提昇包裝品質與產品價值。
- 此機種附有切刀裝置縫袋工作完成時可同步用手動切斷紙帶條與縫線，保持工作的連續性。

Features :

- This model are equipped closing tapping attachment allow users to bind bag tops with crepe paper tape.
- Tape binding reduces sifting of finely divided products and adds a finished appearance to sew bags.
- This model includes a cutter to serve tape and thread at bag edge.
- Removable for convention to standard sewing.

加附喇叭及切刀縫袋口機

Equipped Tapping Attachment



N600AC · N602AC

單線
1-thread

雙線
2-thread

Tape size available :
50 mm , 70 mm

規格 Specifications

| 機種 Model | 線數 Thread | 縫速 Speed | 縫距 Stitch | 使用針 Needle | 切線 Cutter | 淨重 N.W. | 毛重 G.W. |
|-------------|--------------|------------------------|--------------|----------------|-------------------------------|------------|------------|
| N600AC | 1 | 250 ~ 350 Bags/Hour | 7.2 mm | DN x 1 # 25 | 手動切線、紙帶 Manual Tape Cutter | 7.5 kg | 8.9 kg |
| N602AC | 2 | | | | | 8.1 kg | 9.5 kg |

馬達 Drive motor 90W 50 / 60Hz, 1ph / 12V, 24V, 110V, 115V, 220V, 230V, or 240V

(敬請指定 Please specify one when order)



手提式縫袋口機系列 Portable Bag Closer

F300A

單線
1-thread



F302A

雙線
2-thread

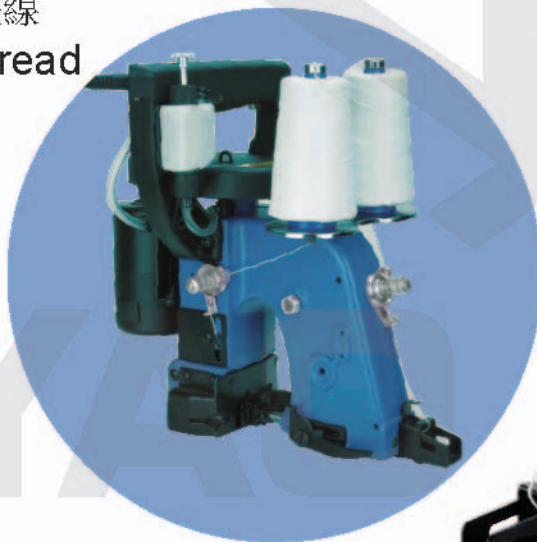

規格 Specifications

| 機種 Model | 線數 Thread | 縫速 Speed | 縫距 Stitch | 使用針 Needle | 切線 Cutter | 淨重 N.W. | 毛重 G.W. |
|-------------|--------------|------------------------|--------------|---------------|--------------------------|------------|------------|
| F300A | 1 | 300 ~ 400 Bags/Hour | 7.2 mm | FD - 5 | 機動切線 | 5.9 kg | 7.3 kg |
| F302A | 2 | | | # 25 | Mechanical Thread Cutter | 6.4 kg | 7.8 kg |

馬達 Drive motor 90W 50 / 60Hz, 1ph / 12V, 24V, 110V, 115V, 220V, 230V, or 240V

(敬請指定 Please specify one when order)



手提式縫袋口機系列 Portable Bag Closer

雙線特厚料縫袋機

Bag Closer for Heavy Use

N320A

雙線
2-thread



特性：

- 強力高壓加油系統，油管伸至各傳動主件，機械運轉與縫袋工作更加順暢。

Features :

- Oil pump lubrication system, oil line directs lubricant to main moving parts.

選配件 Optional

SB-1.5K

1.5 kg affordable

SB-3K

3.0 kg affordable

SB-5K

5.0 kg affordable

SB-7K

7.0 kg affordable

SB-9K

9.0 kg affordable

SB-15K

15 kg affordable



SB-100

Hanging Hook



規格 Specifications

| 機種 Model | 線數 Thread | 縫速 Speed | 縫距 Stitch | 使用針 Needle | 切線 Cutter | 淨重 N.W. | 毛重 G.W. |
|-------------|--------------|------------------------|--------------|----------------|----------------------------------|------------|------------|
| N320A | 2 | 160 ~ 230 Bags/Hour | 8.5 mm | DN x 1 # 25 | 機動切線 Mechanical Thread Cutter | 7.2 kg | 8.6 kg |

馬達 Drive motor 90W 50 / 60Hz, 1ph / 12V, 24V, 110V, 115V, 220V, 230V, or 240V

(敬請指定 Please specify one when order)



移動式縫袋口機系列 Movable Bag Closer

活動式縫袋口機

Moved Closing machine

特性：

- 本機輕巧、操作方便，可任意移動工作地點，設有腳踏開關，方便起動及停止機械。

Features :

- This machine is very easy to handle and convenient to move to a place you need.
- An optional foot switch is available to control head start and stop functions.
- Can increase more productions.

長(L) x 寬(W) x 高(H) = 53 x 52 x 115 cm



MN600A
MN602A

MF300A
MF302A

規格 Specifications

| 機種 Model | 線數 Thread | 縫速 Speed | 縫距 Stitch | 使用針 Needle | 切線 Cutter | 淨重 N.W. | 毛重 G.W. |
|---------------|--------------|-------------|--------------|---------------|--------------------------|------------|------------|
| MF300A | 1 | 300 ~ 400 | 7.2 mm | FD - 5 | 機動切線 | 26.1 kg | 29.6 kg |
| MF302A | 2 | Bags/Hour | | # 25 | Mechanical Thread Cutter | 26.4 kg | 29.9 kg |
| MN600A | 1 | 200 ~ 300 | 7.2 mm | DN x 1 | 機動切線 | 26.3 kg | 29.8 kg |
| MN602A | 2 | Bags/Hour | | # 25 | Mechanical Thread Cutter | 26.7 kg | 30.2 kg |

馬達 Drive motor 90W 50 / 60Hz, 1ph / 12V, 24V, 110V, 115V, 220V, 230V, or 240V

(敬請指定 Please specify one when order)



移動式縫袋口機系列

Movable Bag Closer

特性：

- 縫袋口機高度，可任意調整，適用於各種尺寸的縫袋。
- 工作平台裝置有滑輪，可順利配合縫製時的移動。
- 工作平台左右兩端設有固定螺柱，可防止左右脫滑發生。
- 輕踏腳板開關啟動，工作可快速完成，增加工作效率。

Features :

- Offers manually adjustable pedestal and carriage conveyor combinations for fixed station use of model N600A.
- Flat moving carriage is fitted with grooved wheels for easy motion of the bag past the sewing heads.
- Track is constructed of heavy-grooved angle iron, with rigid cross-brakes the pedestal height is offered 85cm.
- Rubber stops at either end of the track sections limit carriage travel, track length of 120cm.
- An option foot switch is to control sewing head start and stop functions.

FN600A

單線
1-thread

FN602A

雙線
2-thread



規格 Specifications

| 機種 | 線數 | 縫速 | 縫距 | 使用針 | 切線 | 淨重 | 毛重 |
|--------|--------|-----------|--------|--------|--------------------------|---------|---------|
| Model | Thread | Speed | Stitch | Needle | Cutter | N.W. | G.W. |
| FN600A | 1 | 200 ~ 300 | 7.2 mm | DN x 1 | 機動切線 | 55.1 kg | 59.2 kg |
| FN602A | 2 | Bags/Hour | | # 25 | Mechanical Thread Cutter | 55.5 kg | 59.6 kg |

馬達 Drive motor 90W 50 / 60Hz, 1ph / 12V, 24V, 110V, 115V, 220V, 230V, or 240V

(敬請指定 Please specify one when order)



高速縫袋口機系列 High Speed Bag Closing

特性：

- 最高速度 2700 r.p.m.
- 精密零件製造公差配合，運轉順暢，低震動。
- 可配合高速輸送帶生產，每分鐘20公尺(20 m/min)
- 可和舊型機架通用。
- 所有內部零件耐磨及防塵設計。
- 全自動系油系統，零件使用壽命長，維護費用低。
- N980A為一般縫袋口機，並附有機械式切線置。
- N980AC為全自動縫袋口機和紙帶包縫，附有自動氣壓式切線及切紙帶裝置。可用於各種袋類。

Features :

- Max. sewing speed 2700 r.p.m.
- Well balanced rotating parts ensure very little vibration.
- Ideally suited for use high speed bag filling lines where conveyor speeds of 20 m/min.
- Interchangeable with most existing sewing heads.
- All parts are protected against the effects of dust.
- A unique but simple enclosed oil bath lubrication system greatly extends the life of moving parts and reduces maintenance costs.
- N980A is for plain closing, equipped with mechanically operated thread cutter.
- N980AC is an automatic machine for both plain and crepe-tape bound closing, equipped with air operated cutter.

N980A 單針 1-needle

N980AW 雙針 2-needle

適用於平縫
For Plain Sew.



N980AC 單針 1-needle

N980ACW 雙針 2-needle

適用於平縫或配合紙帶條縫合
For Crepe or Plain Sew.



1. 配有氣動切刀。
(使用者需有空壓設備)
 2. 喇叭為選配裝置。
1. Equipped with pneumatic guillotine type crepe tape cutter.
 2. Crepe tape binder is optional.

| 機種 Model | 縫速 Speed Max. / ordinary (r.p.m.) | 車縫厚度 Material Thickness (Max.)(mm) | 縫距 Stitch (mm) | 針、線數 Stitch Type | 切線 Cutter Type | 包縫方式 Closing Type | 空壓 Air Pressure (kg/cm ²) | 空壓消耗 Air Consumption (N /min.) | 淨重 N.W. (kg) | 毛重 G.W. (kg) |
|-------------|--|---|----------------------|------------------------------|--|---|--|---|--------------------|--------------------|
| N980A | 2700 / 2500 | 8 | 7 ~ 11.5 | 單針雙線 1-needle 2-thread | 機動切線 Mechanical Thread Cutter | 僅線包縫 Plain Only | --- | --- | 42 | 44 |
| N980AW | 2500 / 2300 | 8 | 7 ~ 11.5 | 雙針四線 2-needle 4-thread | 機動切線 Mechanical Thread Cutter | 僅線包縫 Plain Only | --- | --- | 43 | 45 |
| N980AC | 2700 / 2500 | 8 | 7 ~ 11.5 | 單針雙線 1-needle 2-thread | 氣動切線 Pneumatic Thread/Tape Cutter | 僅線包縫 Plain Only 線加紙帶 Plain/Tape Bound Closing | 4 | 3.5 | 44 | 46 |
| N980ACW | 2500 / 2300 | 8 | 7 ~ 11.5 | 雙針四線 2-needle 4-thread | 氣動切線 Pneumatic Thread/Tape Cutter | 僅線包縫 Plain Only 線加紙帶 Plain/Tape Bound Closing | 4 | 3.5 | 42 | 44 |
| N980AP | 2700 / 2500 | 8 | 7 ~ 11.5 | 單針單線 1-needle 1-thread | 機動切線 Mechanical Thread Cutter | 僅線包縫 Plain Only | --- | --- | 43 | 45 |
| N980ACP | 2700 / 2500 | 8 | 7 ~ 10.5 | 單針單線 1-needle 1-thread | 氣動切線 Pneumatic Thread/Tape Cutter | 僅線包縫 Plain Only 線加紙帶 Plain/Tape Bound Closing | 4 | 3.5 | 45 | 47 |



高速縫袋口機系列 High Speed Bag Closing

特性：

- 最高速度 2600 ~ 2800 s.p.m.
- 高效性技術革命、低音轉動。
- 高壓強力自動加油系統設計，延長機械使用壽命，增加生產量及降低維護費用。
- 輕易裝置上原有的設備，如平台、各式輸送線等，亦可使用標準單針雙線縫或單線，每英寸可縫二至五針 (7 ~ 12 mm)。
- 可用於紙袋、麻袋、塑膠編織袋、麵粉袋、棉袋、PP和PE袋。

Features :

- Max. sewing speed 2600~2800 s.p.m.
- High speed obtained with low vibration.
- Is designed to have long-range smooth performance with low vibration, and the latest innovations in trouble-free-bag-sewing technology.
- Self-lubrication system protects moving parts and ensure maximum productivity with low maintenance.
- Easily adaptable to your existing equipment, can use with standard two thread stitch or 1-thread stitch and stitch width is adjustable from 2~5 stitches per inch (7~12 mm).
- For bag closing all kinds of paper, cotton, PP/PE, hessian, jute, etc.

F900A 1-needle
2-thread
chain stitch
單針雙線縫

F900AC 1-needle
2-thread
chain stitch
單針雙線縫



配備自動氣壓裝置，
可切線及紙帶條。
Pneumatic Cutting
Thread and Tape.

| 機種 Model | 縫速 Speed (r.p.m.) | 車縫厚度 Material Thickness (Max.)(mm) | 縫距 Stitch (mm) | 針、線數 Stitch Type | 縫樣 Closure Type | 切線 Cutter Type | 切紙帶 Tape Cutter | 空壓 Air Pressure (kg/cm ²) | 空壓消耗 Air Consumption (N /min.) | 淨重 N.W. (kg) | 毛重 G.W. (kg) |
|---------------|-----------------------------------|---|----------------------|---|--|--------------------------------|--------------------------------|--|---|--------------------|--------------------|
| F900A | 80 feet (2438cm) / per min. | 8 | 7 ~ 12 | 單針雙線縫 1-needle 2-thread chain stitch | 標準縫 Standard sew | 裁切型切刀 Guillotine style | Non | --- | --- | 30 kg | 29 kg |
| F900AC | 80 feet (2438cm) / per min. | 8 | 7 ~ 12 | 單針雙線縫 1-needle 2-thread chain stitch | 標準縫 Standard sew 紙帶縫 Tape sew | 氣壓控制 Auto scissors style | 氣壓控制 Auto scissors style | 4 | 3.5 | 33 kg | 34 kg |



高速縫袋口機系列

High Speed Bag Closing

特性：

- 最高速度 2600 ~ 2800 s.p.m.
- 高效性技術革命、低音轉動。
- 高壓強力自動加油系統設計，延長機械使用壽命，增加生產量及降低維護費用。
- 輕易裝置上原有的設備，如平台、各式輸送線等，亦可使用標準單針雙線鏈縫或單線，每英寸可縫二至五針 (7 ~ 12 mm)。
- 可用於紙袋、麻袋、塑膠編織袋、麵粉袋、棉袋、PP和PE袋。

Features :

- Max. sewing speed 2600~2800 s.p.m.
- High speed obtained with low vibration.
- Is designed to have long-range smooth performance with low vibration, and the latest innovations in trouble-free-bag-sewing technology.
- Self-lubrication system protects moving parts and ensure maximum productivity with low maintenance.
- Easily adaptable to your existing equipment, can use with standard two thread stitch or 1-thread stitch and stitch width is adjustable from 2~5 stitches per inch (7~12 mm).
- For bag closing all kinds of paper, cotton, PP/PE, hessian, jute, etc.

F900AT 1-needle
2-thread
chain stitch
單針雙線鏈縫

F920A 2-needle
4-thread
chain stitch
雙針四線鏈縫

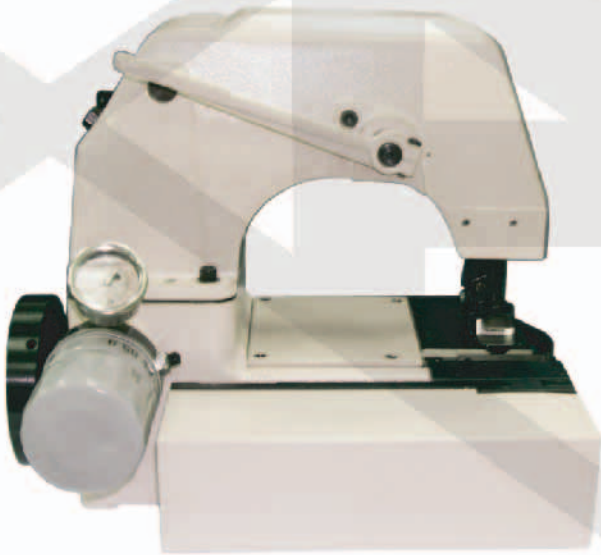

鐮刀型切刀
(只可切線)

Pneumatic Rotary Knife
(Cutting Thread only)



| 機種 Model | 縫速 Speed (r.p.m.) | 車縫厚度 Material Thickness (Max.)(mm) | 縫距 Stitch (mm) | 針、線數 Stitch Type | 縫樣 Closure Type | 切線 Cutter Type | 切紙帶 Tape Cutter | 空壓 Air Pressure (kg/cm ²) | 空壓消耗 Air Consumption (N./min.) | 淨重 N.W. (kg) | 毛重 G.W. (kg) |
|-------------|-----------------------------------|---|----------------------|--|-----------------------|--|-----------------------|--|---|--------------------|--------------------|
| F900AT | 80 feet (2438cm) / per min. | 8 | 7 ~ 12 | 單針雙線鏈縫 1-needle 2-thread chain stitch | 標準縫 Standard sew | 鐮刀型切刀 Pneumatic rotary knife style | Non | 4 | 4 | 33 kg | 34 kg |
| F920A | 80 feet (2438cm) / per min. | 8 | 7 ~ 12 | 雙針四線鏈縫 2-needle 4-thread chain stitch | 標準縫 Standard sew | 截切型切刀 Guillotine style | Non | --- | --- | 30 kg | 31 kg |



高速縫袋口機系列

High Speed Bag Closing

特性：

- 高速重型縫袋口機
- 適車縫粗麻布, 黃麻, 聚酯纖維, 棉, 塑膠, 紙等材質。

Features :

- High Speed, Heavy Duty Bag Closing Machines
- for Closing Filled Bags Made from Burlap, Jute, Woven Poly, Cotton, Plastic, and Paper.

YH-80800C

單針雙線鏈縫





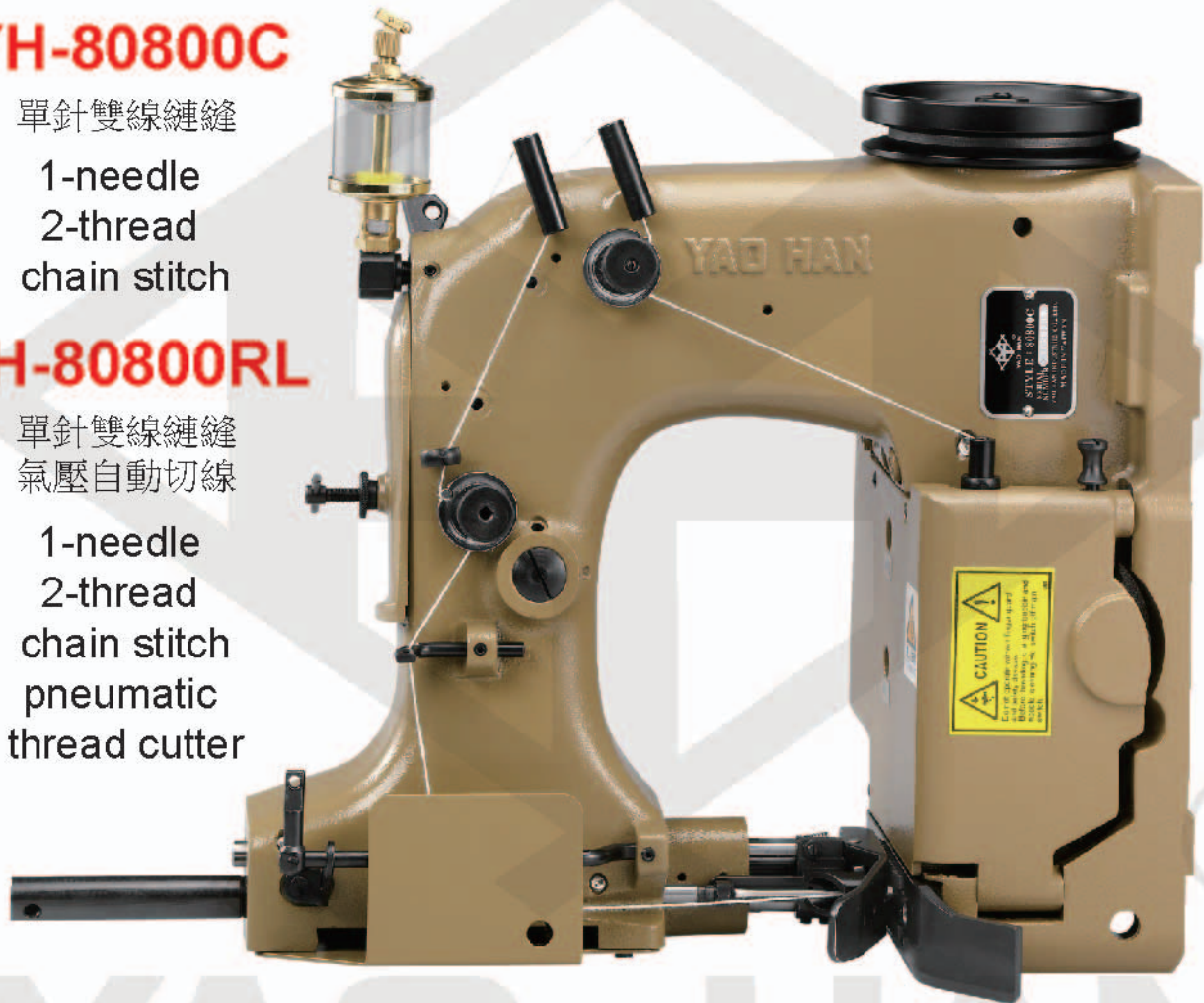

1-needle
2-thread
chain stitch

YH-80800RL

單針雙線鏈縫
氣壓自動切線

1-needle
2-thread
chain stitch
pneumatic
thread cutter



|  |  |  |  |  |  |  |
|---|---|---|---|--|---|---|
| YH-80800C | 1 800-0453 | 2 | - | 2 1/2-4 SPI (6.5 - 11mm) | 11mm | 1800 RPM |
| YH-80800RL | 1 800-0453 | 2 | - | 2 1/2-4 SPI (6.5 - 11mm) | 11mm | 1800 RPM |



輸送帶式縫袋口機系列

Automatic Bag Closing with Conveyor

特性：

- 包帶縫合自動包裝機適用於紙袋袋口的包紙帶和縫合，在糧食、飼料、化工等行業得到廣泛的應用。
- 該機採用光電控制，能自動連續完成紙袋袋口的修剪、包紙帶、縫合、剪紙帶、剪線辯等工序。其氣動系統實現線剪斷的工作。
- 該機可以與自動計量灌裝及輸送機組成自動生產線。

Features :

- Automatic infeed and bag top trimming device for crepe-tape bound closure on paper bags. Applicable to factories of grains, feedstuff, chemical, coffee beans, and etc.
- Photo-electric start, stop, and cutting controls. Bag top trimming, paper tape binding, stitching, paper tape snipping and thread cutting can be finished automatically.
- Designed for automatic production line with auto-ration filling machine and conveyor.



TP1

包邊送袋機

(適用於平縫或配合紙帶條縫合)

Automatic Infeed Device.

(For Tape or Plain Sew Bag Closers.)

FACCC-N980AC

光電開關控制

車縫啟動 / 停止；氣壓切線 / 切紙帶。

(氣壓壓力 4 kg / cm²)

Photo-Electric Start, Stop and Cutting, Pneumatic Cutting Thread and Crepe Tape.

(Control Within 4 kg / cm²)

● 輸送帶 Conveyor :

淨重 N.W. 175 kg, 毛重 G.W. 315 kg, 長 length x 寬 Width x 高 Height : 317 x 74 x 66 cm

● 架台與機頭 Pedestals and Sewing Head (F900AC) :

淨重 N.W. 295 kg, 毛重 G.W. 335 kg, 長 length x 寬 Width x 高 Height : 129 x 128 x 190 cm

● 架台與機頭 Pedestals and Sewing Head (N980AC) :

淨重 N.W. 300 kg, 毛重 G.W. 430 kg, 長 length x 寬 Width x 高 Height : 126 x 125 x 187 cm

| 機種 Model | 縫速 Speed | 使用針 Needle | 縫距 Stitch | 裁樣 Cutter Type | 車縫厚度 Material Thickness | 縫目型式 Stitch System | 馬達 Motor | 車頭高度調整距 Height Adjustment Range | 工作平台規格 Work Plate Size |
|-------------|------------------------|----------------|--------------|--------------------------|-------------------------------|--------------------------|-------------------------|---------------------------------------|------------------------------|
| FACC-N980AC | 500 ~ 600 Bags/Hour | DR x 2 # 26 | 7 ~ 11 mm | Pneumatic Thread/Tape | 8 mm | Double Chainstitch | 3 Hp / 220V 1 / 2 Hp | 720 ~ 1200 mm | 450 x 300 mm |



縫袋機架台系列

Pedestals for Bag Sewing Heads

特性：

- F900A與N980A系列機頭，皆可安裝到FA與FB架台上。
- FA / FB 可調整高度：75 ~ 140 cm。

Features：

- Both F900A and N980A series sewing heads can fit on both FA and FB pedestals.
- The height of FA/FB pedestal is adjustable：75~140 cm.



FA-N980A



FA-N980AC



FAC-N980AC



FB-N980A

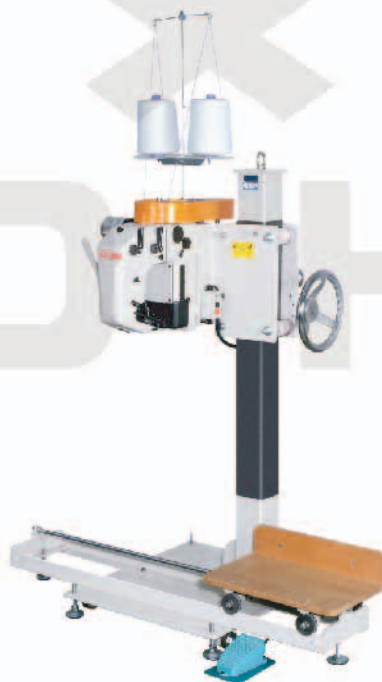

FB-F900A



FB-F900AC



厚物用地毯包邊機

Heavy-Duty Overedging Machine

YH-2502K



YH-2503B

繩網包縫機
Overedging Machine
for Net



適用於包縫各式繩網，
如球網、漁網等。

Suitable for overedging
all kinds of nets, for
example ball nets,
fish net, and etc.

YH-2503C

毛毯飾邊包縫機
Overedging Machine for Blankets

適用於地毯、毛毯、麻袋等厚類布料之包邊。

Suitable for overedging on tufted carpets, rugs,
blankets, jute, polypropylene bags, and any
extra heavy materials.



雙線 2-thread

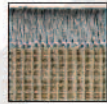
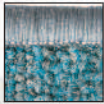

三線 3-thread

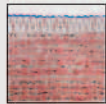
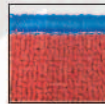

YH-2501K

地毯及厚料接布機
Carpet & Cloth Abutted Machine

適用於地毯或其他厚類、寬邊布料之接布用途。
Suitable for various carpets or extra-heavy materials
temporary abutted stitching for dyeing purpose.



YH-2600

拉布機 (右)
Puller (Right-Hand)

YH-2600L

拉布機 (左)
(Left-Hand)

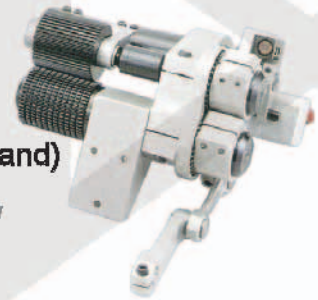

YH-2500A

氣動式抬押腳 (右)
Pneumatic Presser Foot-Special
Accessory for Carpet Overedging
Machine.

YH-2500AL

氣動式抬押腳 (左)
(Left Hand.)



氣動式抬押腳搭配
地毯包邊機使用，
操作更加輕鬆方便。
安裝於YH-2500
系列地毯包邊機。

The pneumatic presser
foot for carpet overedging
machine will make the
operation of the machine
easier and more convenient.
YH-2500A is suitable for YH-2500 series machine.

| 右手車 Right Hand | 左手車 Left Hand | 線數 Stitch Type | 修邊刀 Cutting Device | 縫距調整裝置 Stitch Adjusting Device |
|-------------------|------------------|-------------------|-----------------------|-----------------------------------|
| YH-2502 | YH-2502L | 雙線 2-thread | | |
| YH-2502N | YH-2502LN | 雙線 2-thread | | ● |
| YH-2502K | YH-2502LK | 雙線 2-thread | ● | |
| YH-2502NK | YH-2502LNK | 雙線 2-thread | ● | ● |
| YH-2503 | YH-2503L | 三線 3-thread | | |
| YH-2503N | YH-2503LN | 三線 3-thread | | ● |
| YH-2503K | YH-2503LK | 三線 3-thread | ● | |
| YH-2503NK | YH-2503LNK | 三線 3-thread | ● | ● |



YH-2500N Series

新專利：縫距調整裝置

New Patent :Stitch Adjusting Device.

新專利
New Patent



耀瀚股份有限公司
YAO HAN INDUSTRIES CO., LTD.

<http://www.yaohan.com.tw>

YAO HAN (Taiwan) Head Office & Factory
No.31, Lane 145, Fuying Rd., Xinzhuang Dist.,
New Taipei City 242, Taiwan
TEL : 886-2-2904-2223 FAX : 886-2-2903-3598
E-mail : es@yaohan.com.tw

YAO HAN(Hong Kong) Branch Office
7/F., Airgoal Cargo Building, 330 Kwun Tong Road,
Kwun Tong, Kowloon, Hong Kong
TEL : 852-27508832 FAX : 852-27576433
E-mail : yaohan@yaohanhk.com

YAO HAN (China) Branch Office
201, Building 1, Lane 5, Zhuwan Village, Nanlian Community,
Longgang Street, Longgang District, Shenzhen City, China
TEL : 86-755-89359689 FAX : 86-755-89901057
E-mail : yaohan.cnws001@gmail.com

2014.03