



HO HSING

突破進化限制，數位控制得心應手。

Evolution breakthrough, handy operation with digital control.

HVP-9E SERIES

AC Servo Motor

••••DIGITAL••••

# HVP-9Evolution

適用於三本車。

Suitable for chain stitch machine.

安裝簡單，操作輕鬆。  
 交換式電源供應系統，更省電，更安全。  
 微電腦控制，軟硬體雙向保護機能，產品壽命更長久。  
 一針到位及多種定位模式，讓您操控更得心應手，提升作業效率。  
 參數設定由數位控制面板直接存取。  
 環保節能電路設計，符合各類安規及RoHS指令，低污染，讓我們為環保盡一分心力。

Simple installation, easy operation.  
 Switching power supply system, safer and better for energy saving.  
 CPU control, software / hardware 2-way protection system, prolonging the product life.  
 One-shot positioning and multi-positioning modes, operation is handy and raise your work efficiency.  
 Parameter setting with digital control panel.  
 ECO-circuit design, conform to each safety standard and RoHS directive,  
 less pollution, let us do our part to preserve the environment.



賀欣機械廠股份有限公司  
 H.S.MACHINERY CO., LTD.  
<http://www.hohsing.com>

CERT.NO.3A1Y004-03 CERT.NO.IGICN070327

## Specification / 規格

Actual weight might be different depend by the varied accessories  
實際重量會依配件的不同而有所差異

Function	機能	HVP-9E
Motor Type	電機出力	550W-3000 rpm. (轉)
Power Voltage Range	電壓範圍	Single Phase (單相) : 200~240V
		Three Phase (三相) : 380~400V
Pulley Size Available	皮帶輪尺寸	65 ~ 110 mm
External 12V LED Socket	外接 12V LED 插座	★
Needle UP / DOWN	停針 上 / 下	★
Soft Start	慢速啟動	★
Reverse at Stop	停針反轉	★
Power Module Protection	模組保護	★
Trimming (MT)	剪線 (MT)	★
Wiping (MW)	撥線 (MW)	★
Back Tacking (MR)	加固縫 (MR)	★
Tension Release (ML)	鬆線 (ML)	★
Presser Foot (MP)	押腳 (MP)	★
Input Signal Port	入力信號數	6
Solenoid Signal Output Port	電磁鐵出力信號數	5
Gross Weight - kg	毛重 - 公斤	550W= 14.3(16) *
Packing Dimension	包裝尺寸	420(L) X 350(W) X 259(H) mm

(\*) = Weight for 380V / 380V的毛重

## Dimension / 尺寸圖

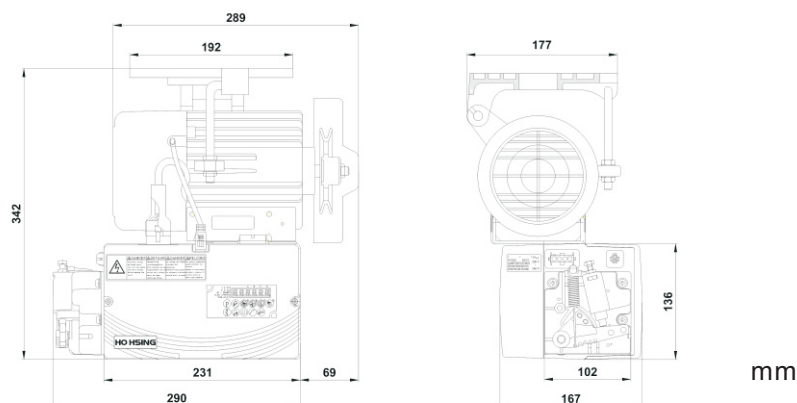

## Model Code / 編碼規則

HVP-9E-4-66-2 20-CE

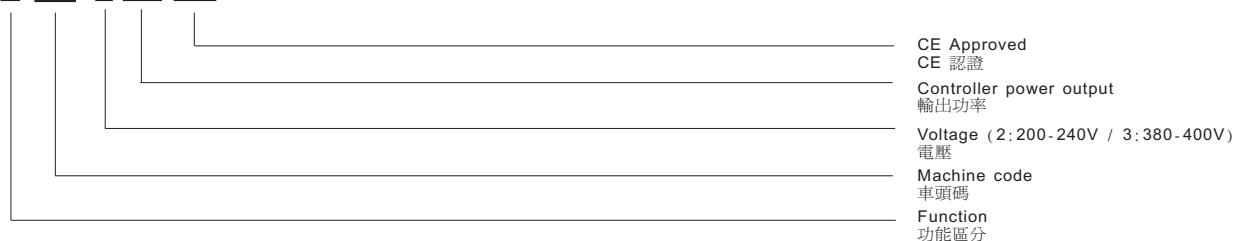

All the technical data, dimensions and weights are for reference only, and are subject to change without notice.  
For other products information please contact our sales representative or visit our web site at [www.hohsing.com](http://www.hohsing.com)



賀欣機械廠股份有限公司  
H.S.MACHINERY CO., LTD.

台北縣樹林市中正路632巷5號  
NO. 5 LANE 632 CHUNG CHENG RD.,  
SHULIN CITY, TAIPEI HSIEN, TAIWAN

TEL : +886-2- 2689-5501~2 (REP.)  
+886-2- 2688-5742, 2688-6044  
SERVICE : +886-2676-5203  
FAX : +886-2- 2689-6600, 2689-3657  
E-MAIL : sales@hohsing.com.tw

<http://www.hohsing.com>